



Trade +
Contract



MADE TO STAND UP + STAND OUT.

BLUDOT.COM

TRADE + CONTRACT

trade@bludot.com

844.425.8368x4

M-F, 9-5 CT



Cats Pajamas Lounge Chairs

WE GOT YOU.



Acre Lounge Chairs



Trade + Contract

5-YEAR WARRANTY ON ALL BLU DOT DESIGNS

We design

everything

we make.

WE DO CUSTOM DESIGN TOO.

DESIGNED IN MINNESOTA SINCE 1997.

We love what we do.

(Thanks for that.)

BIFMA TESTED

All the digital tools to get it done.

3D Files
WYS
Specs

STORES IN:
NEW YORK
WASHINGTON, DC
MIAMI
CHICAGO
AUSTIN
LOS ANGELES
SAN FRANCISCO
PORTLAND
SEATTLE
DALLAS
SYDNEY
MEXICO CITY
MONTERREY
+ MORE

WINNER OF COOPER HEWITT NATIONAL DESIGN AWARD IN 2018.

Remember faces?

JOHN, A COUPLE IDEAS:

BLUE DOT

BLUE DOT DESIGN & FINE
MINNEAPOLIS, MN 55401
TEL: 612-322-5714
WWW.BLUE-DOT.COM

BLUE DOT DESIGN
4556 HWY 10
MINNEAPOLIS, MN 55412
TEL: 612-322-5714
WWW.BLUE-DOT.COM

BLUE DOT DESIGN & FINE
4556 HWY 10 SOUTH
MINNEAPOLIS, MN 55401
TEL: 612-322-5714

BLUE DOT
812-825-5714

(MORE LATER)

MAKING IT COOL SINCE 1997.

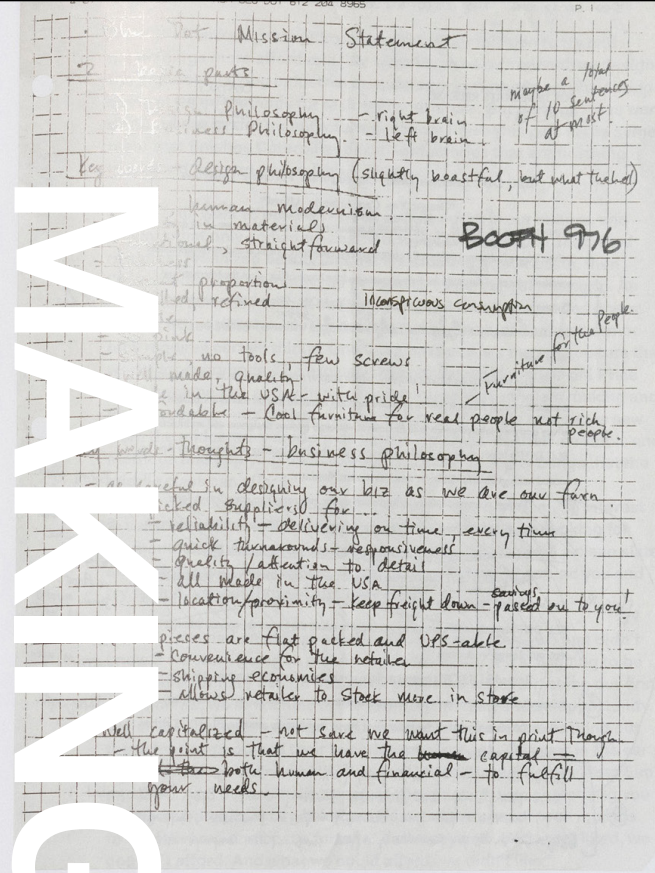

Christakos in the Blu Dot
and offices, circa 1998
Christakos, Julie Pihaly,
Whant, and John Christakos
(in right) at the Blu Dot
1998
Lazor in the Blu Dot
1998

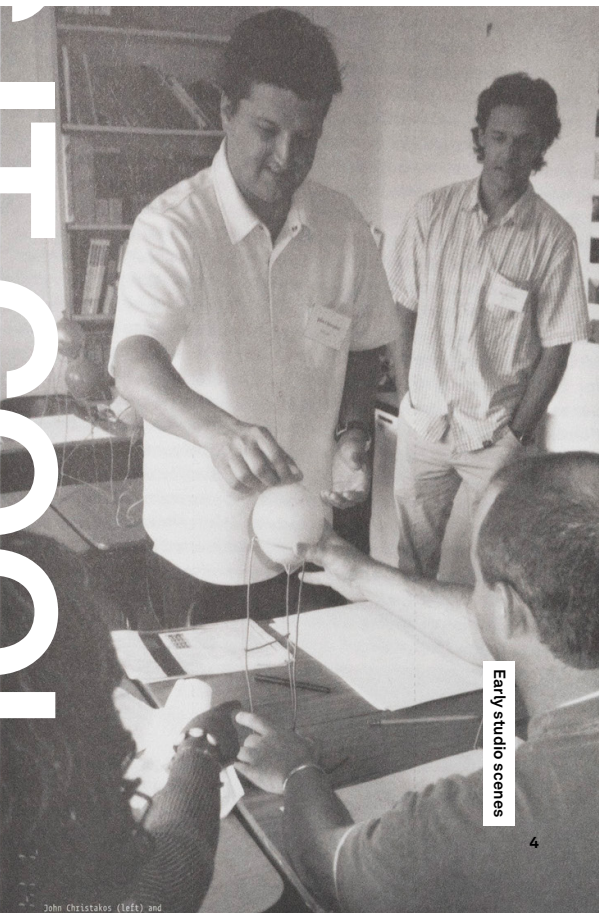

Early studio scenes

John Christakos (left) and

WHERE IT ALL BEGAN.

Our very first designs were sketched on a shared roll of butcher paper spread across a long table. Three friends—two architects and a sculptor—dreaming and designing. The early makings of a humble venture inspired by our own futile search for desirable and affordable modern designs.

Our goal then, as it is now, is to bring good design to as many people as possible. We never imagined that over 25 years later, we'd be lucky enough to still be designing purposeful and beautiful objects in our Minneapolis studio. Only now we do it with an incredibly talented team of fellow design lovers (and a much longer table).

Together, we've built a business that not only supports our design habit, but lets us have our hands on the whole process, from product development through the customer experience. It's how we design pieces that are in it for the long haul. Some of our most popular designs today were part of our very first collection. We hesitate to call anything an "icon," but we're working on it!



Prototypes



Maurice Blanks and John Christakos, Founders



Offline Outdoor Chair Prototype



TWEAK. REPEAT.
PROTOTYPE.
SKETCH.

Souvenir Sofa | Nest Bowls | Super Swivel Table

WE DESIGN EVERYTHING WE MAKE.

Good design takes time, patience and often, a heap of prototypes to get it right. Before you see anything new from us, we've already seen it a hundred times. We've sketched it, constructed small scale models of it, contemplated it (endlessly) and tested its scale, proportion, feel—every inch of it.

We're closely involved in every step of the process, from each design's conception to its safe arrival at your door. It's how we ensure everything we create is as special and well-made as possible. Designs that we're proud to call our own and excited to bring into our own homes and offices.

How do we decide what to design next? We look around to discover a need. Sometimes we find it after scrutinizing our current collection. Or we might get inspired by a desire to solve a simple problem. Often, we explore our own spaces to consider what could make every day easier and more enjoyable for all of us.



Prototype

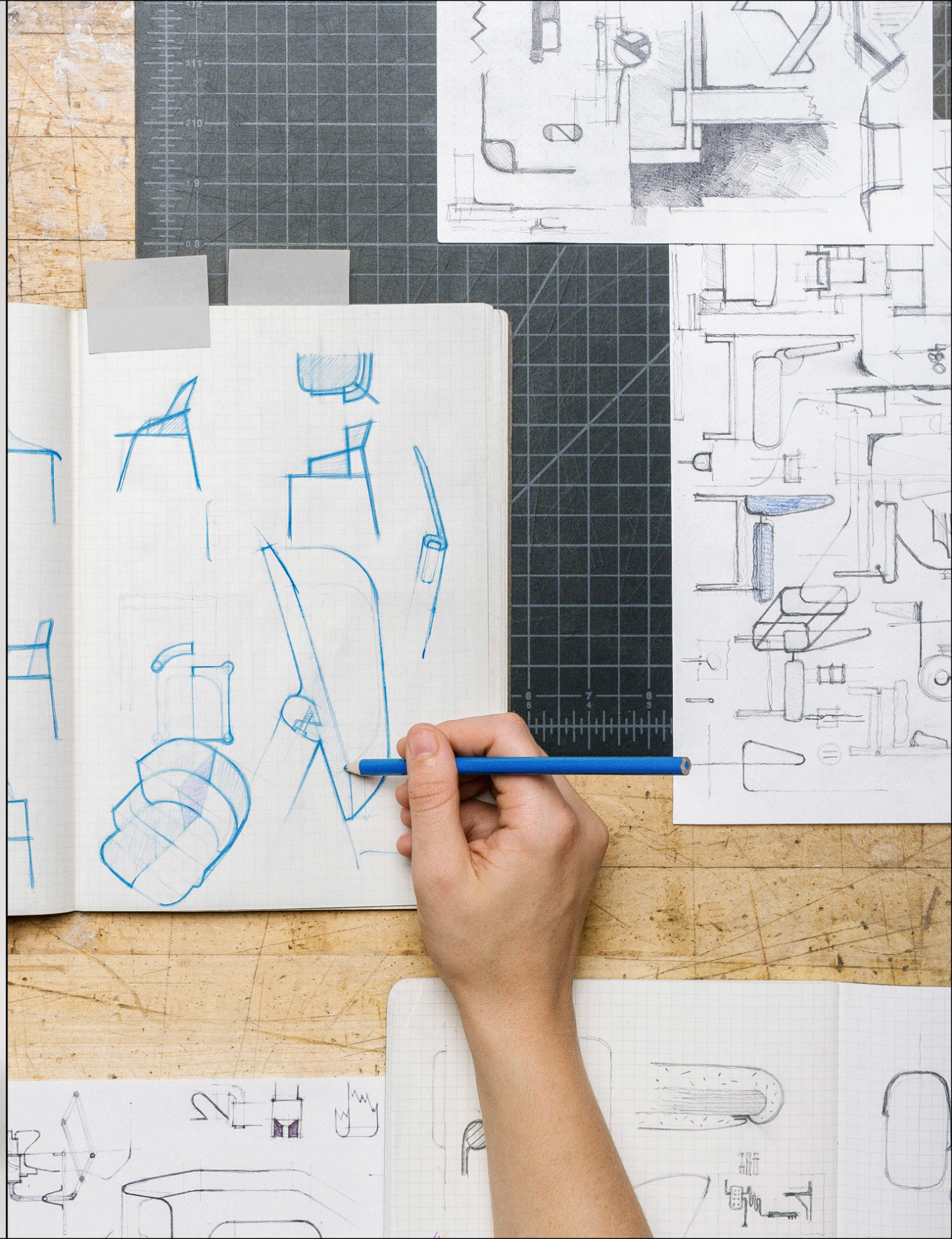



Decade Chair

DURABLE, CLEANABLE, STACKABLE, CAPABLE.
Our goal with the Decade Chair was to create a timeless plastic chair that could last for a good long time and work indoors or out. We initially designed it as two pieces, but scrapped it for a simple one-piece silhouette. This kept the look crisp and allowed the chair to stack right on the frame, making the most of every millimeter.



Decade Chair sketches and prototypes

SNAZZY NOT STUFFY.

Our Hands Down Sofa was bred from our desire to create a tailored sofa that invites relaxation. We chose a variety of pillow sizes for a more flexible, customized seating experience. A single-seat bench cushion allowed for the perfect sit, providing a nice initial “sink” without making you feel stuck on the sofa—unless that’s what you’re going for.



Hands Down Sofa 3D Sketch



Hands Down Sofa | Good Times Coffee Table | Variant Vase



Perch Lounge Chair prototype and sketches

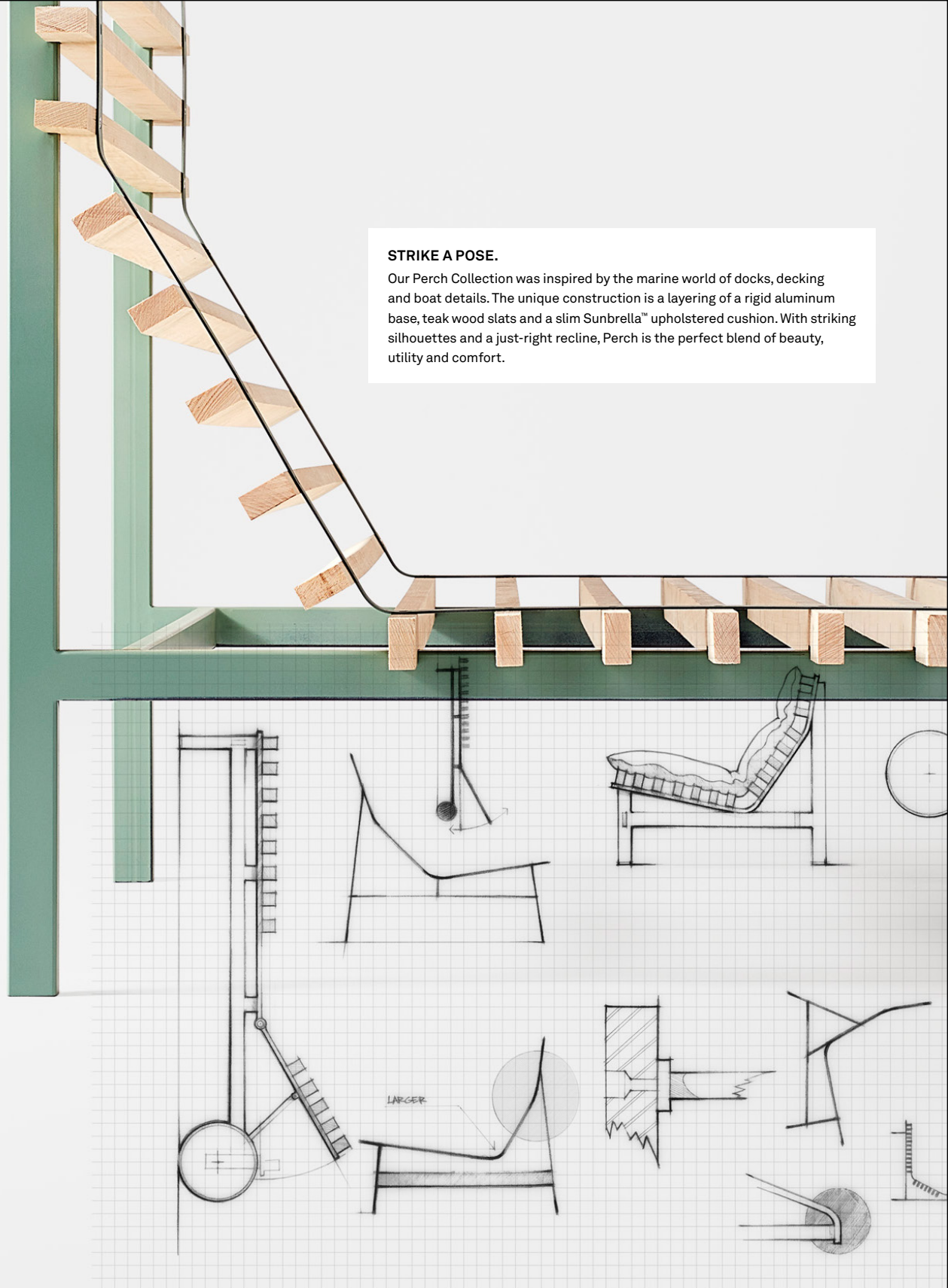

STRIKE A POSE.

Our Perch Collection was inspired by the marine world of docks, decking and boat details. The unique construction is a layering of a rigid aluminum base, teak wood slats and a slim Sunbrella™ upholstered cushion. With striking silhouettes and a just-right recline, Perch is the perfect blend of beauty, utility and comfort.

WE'VE GOT THE RECIPES.



AWARD-WINNING DESIGNS? YEP.

The National Design Awards, AKA the “Oscars” of designs, were conceived by Cooper Hewitt, Smithsonian Design Museum to honor lasting achievement in American design. The Awards are given in recognition of excellence, innovation, and enhancement of the quality of life.

An interdisciplinary jury selected Blu Dot as the winner in Product Design — choosing us for our body of work, as well as our mission of making design more democratic. Past honorees include Jonathan Ive, Eva Zeisel and Herman Miller. We’re humbled and delighted to see our name alongside these revolutionary designers.

We’re proud of all our designs, but especially the award-winning ones. (And there are many.) Take a peek at our assortment, and you’ll find Best of Year Awards Finalists, NYCxDesign Awards Finalists, A+Product Awards Finalists, Good Design Award Winners and Interior Design Magazine Best of Year Winners, to name a few.



Bonnie & Clyde Sectional Sofa | Hoopla Mirror | Construct Marble Console + Nightstand | Punk Lamp
Coco Low Side Table | Swale Coffee Table | Perimeter Pendant Lights | Bobber Table Lamp





Host Dining Chair | Strut Table

EVERY SPACE IS OUR SWEET SPOT.

Whether you need a couple of unique pieces to pull a flexible workspace together, a custom solution for a café or you're furnishing an entire office space, we're happy to help bring your vision to life.

WE WORK WHERE YOU WORK.

We teamed up with the folks at The Coven, a coworking space whose mission is to create a more equitable community. They wanted a modern, yet comfortable space where people felt empowered to work or just kick up their feet. Most of all, it needed to make people feel joy. Their bright interiors + our colorful designs. Mission accomplished.

Bank Sofa | Bloke Lounge Chairs | Puff Puff Lounge Chair | Bumpers



Lalika Pendant Lights | Racon Counter Stools | Bliss Dining Chairs | Decade Chairs



MADE TO HANDLE THE BRUNCH BUNCH.

Birdy's Behind the Bower is a gorgeous brunch spot nestled in New Orleans' Lower Garden District. They needed a space that, like their branding, felt chic, yet fun. From compelling pendant lights to versatile chairs, Birdy's designers filled the interior with eye-catching Blu Dot designs that can stand up to regular brunches and bottomless mimosas.



Tangent Lounge Chair

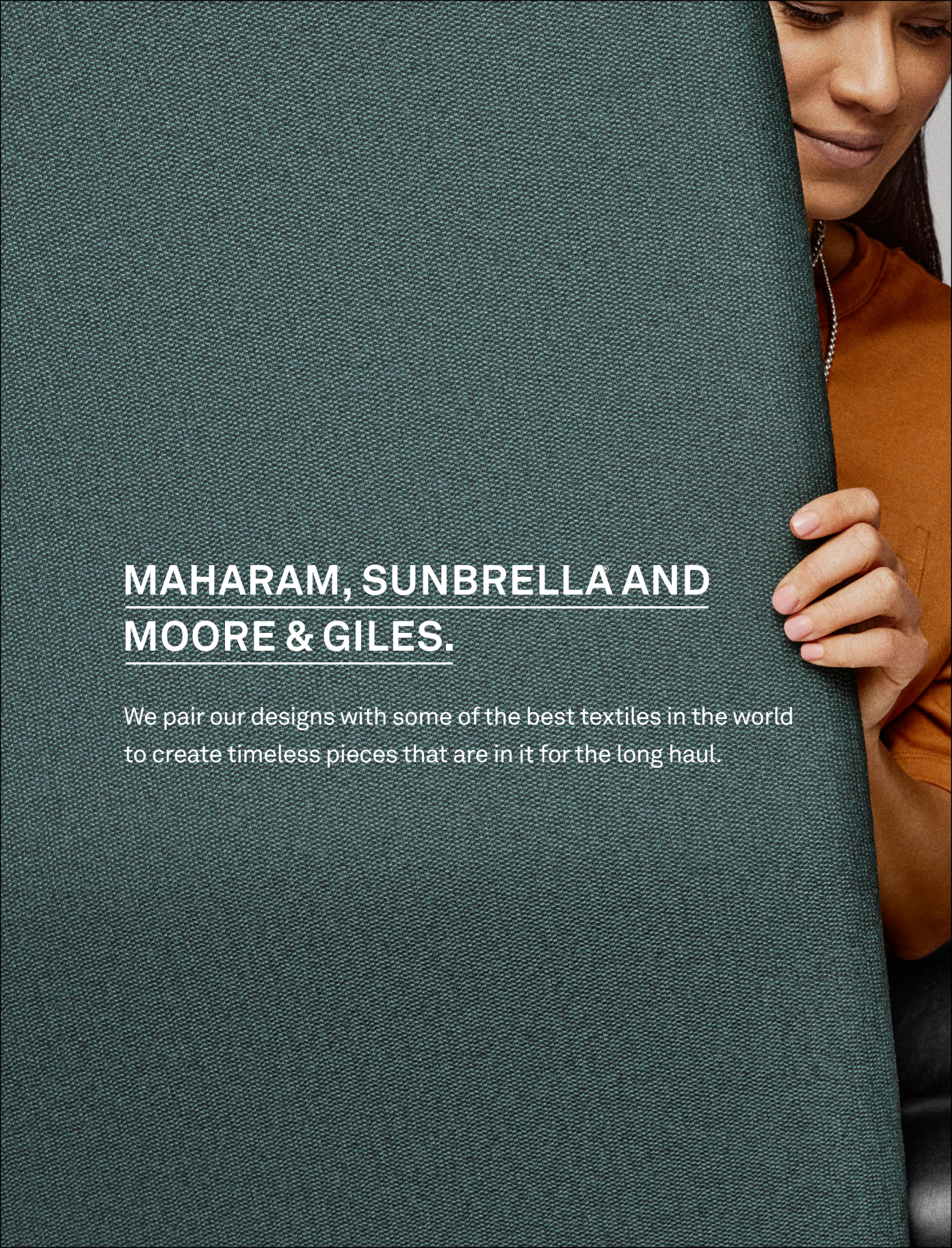

MAHARAM, SUNBRELLA AND MOORE & GILES.

We pair our designs with some of the best textiles in the world to create timeless pieces that are in it for the long haul.

GIVE YOUR FAVORITE DESIGNS SUPERPOWERS.

Maharam fabrics are durable, stain-repellant, and made almost entirely of recycled content. They also meet low chemical emissions and VOCs standards, making them a beautiful no-brainer for home or office.



Puff Puff 67" Sofa | Field Lounge Chair | Host Dining Chair | New Standard 92" Sofa | Heads Up Lounge Chair

Host Task Chair | Open Plan Desk | Beau Table Lamp | Square One Stacking Trays

AGING GRACEFULLY GUARANTEED.

Moore + Giles is known for designing and developing some of the world's finest natural leathers. Experts at their craft, they offer a wide range of finishes and colors to keep all of our leather designs timeless and on trend.



Bonnie Sofa



LET'S TAKE THIS OUTSIDE.

Sunbrella® fabric stands the test of time and keeps your furniture well-dressed for all occasions. Durable, stain-repellant and easy to clean, it's ready to brave the elements come rain, shine or red wine.

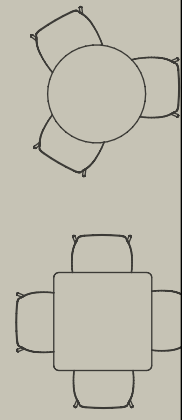
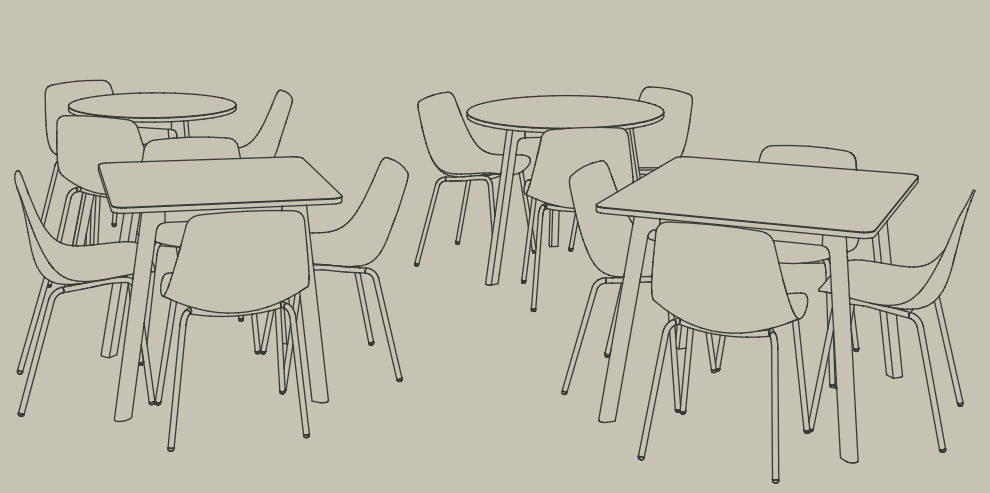
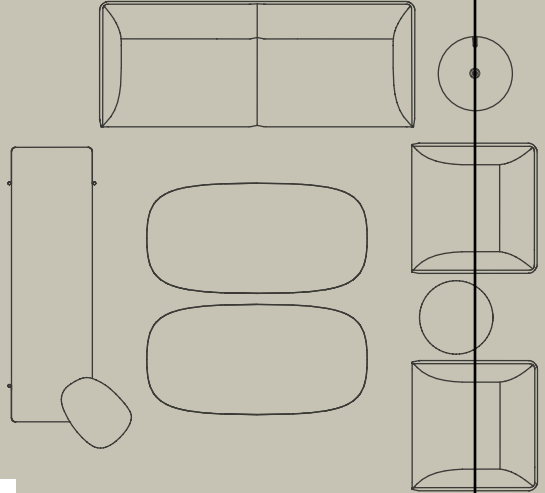
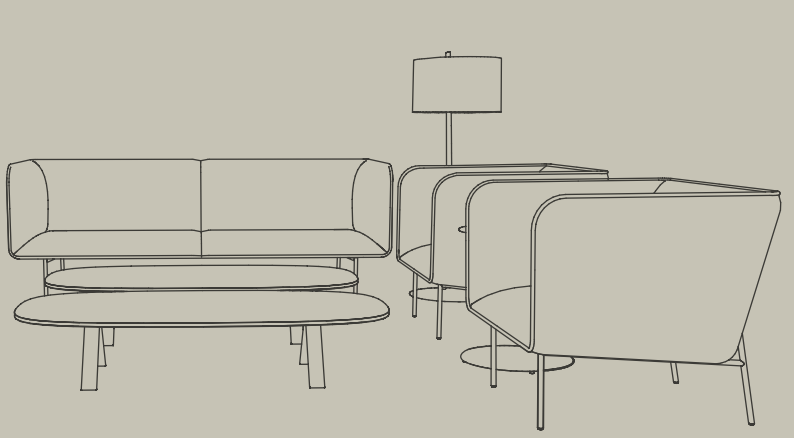

WORK YOUR SPACE.
 Our Trade + Contract site has all the design tools you need to make your next project your best project. Need ideas for conference room layouts? Looking to liven up a lobby? We got you. Our handy Work Your Space Guide features a collection of new designs and bestsellers assembled into functional groupings. Reference it for inspiration or to help take a little work out of your work.

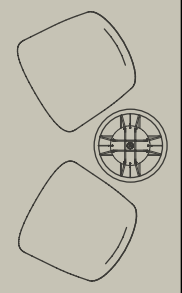
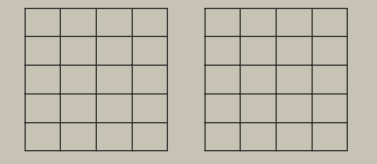
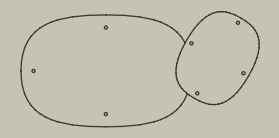
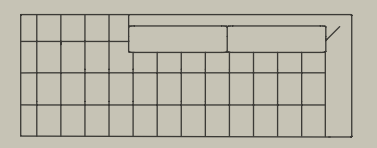
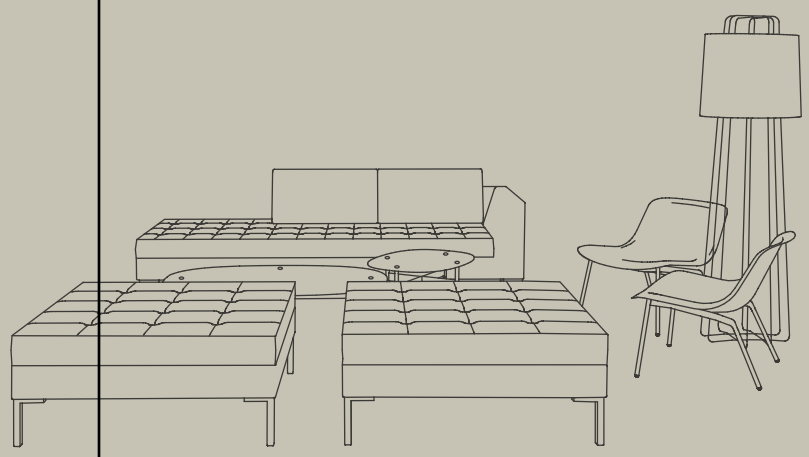
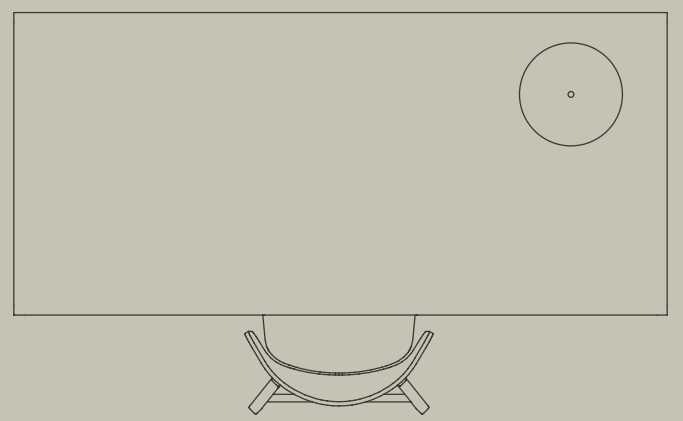
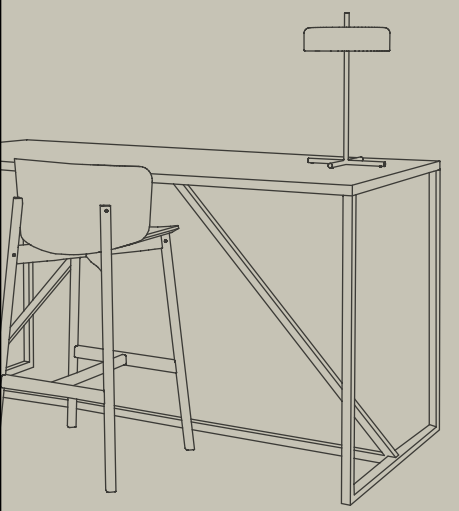
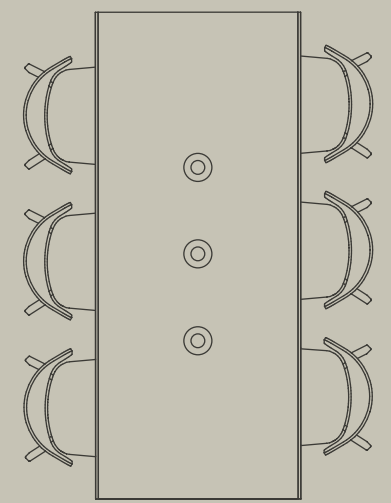
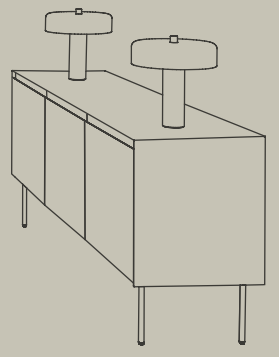
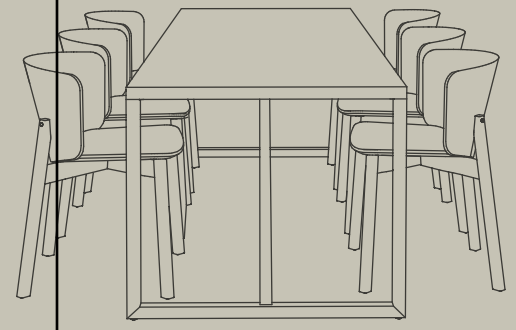
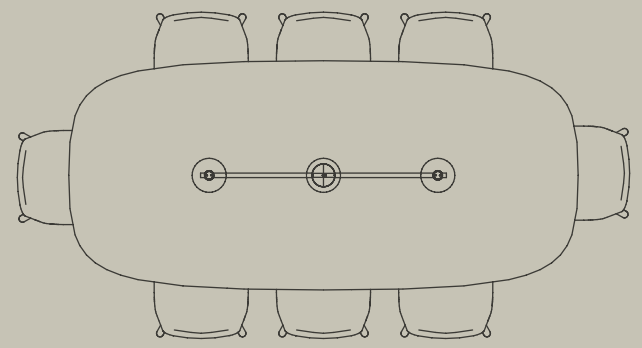
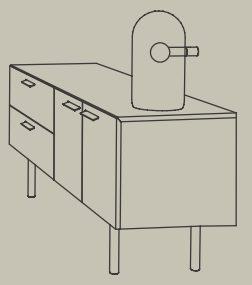
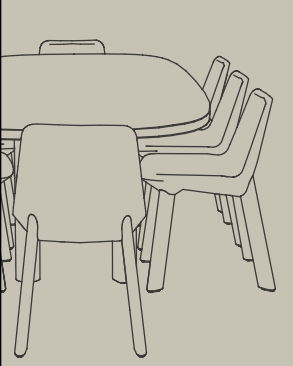
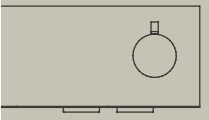



Good Times Dining Table | Racer Dining Chairs | Delicious Marble Trays | Fancy Rug



Bully Table Lamp | Nest Bowl

BIFMA TESTED. UL LISTED.

Our original, contract-quality designs are backed by a 5-year warranty and are suitable for projects big and small, in any commercial environment. We put each design through the paces to make sure it can handle the rigors of life.



FEEL GOOD FACTOR.

Dibs Dining Chair

LOVE THE DESIGNS YOU'RE WITH.

We believe design should do more than just look good. It needs to consider how each of us live and work, finding creative ways to make both easier and more delightful. To that end, we thoughtfully design every piece to have personality and a purpose.

We carefully consider where and how each design will be used, what need it solves and how it can not only stand out, but stand up to whatever life throws at it. Every decision we make is guided by the goal of creating pieces that everyone loves living with as much as we do.

What does all this contemplation lead to? One of a kind silhouettes, rich color palettes and unexpected materials working together to create designs that help you live better, work smarter and brighten a room just by being in it.

LOUNGE CHAIR OF THE YEAR. NBD.

Our Field Lounge Chair was designed to be a chair that you can really sink into and one that can really hold a room. We shaped the arms and body to work as one, creating a simple, sculptural form. We topped it off with sumptuous upholstered cushions and a powder-coated steel base. The result is one of our most comfortable (and most loved) chairs. Not to mention, winner of the Best Lounge Chair of the Year from Interior Design Magazine.





ALL-WEATHER WONDER.
Not every design requires the reinvention of the wheel. With the goal of creating our own quintessential café chair, we revisited the classic European bistro chair lexicon. Powder-coated steel forms a simple, stackable tubular frame. To finish the seat and back, we created our own bold graphic pattern, turning a hot mess into Hot Mesh.

DANG IT ANY WAY.

Our bestselling Dang Collection. Powder-coated steel and wood pair with unlacquered brass details to create an unassuming silhouette that's pretty (perfect) in every space. Available in a variety of shapes and colors to add fun and function wherever it goes.





Lap Credenza | Hoopia Mirror | Beau Table Lamp | Flange Vessels



Strut Tables | Splash Coctrack





WOOD IS GOOD.

Our Port Dining Chair celebrates the natural beauty of wood in a unique way. The upward curvature of the seat not only accentuates comfort, but adds strength and structure. Port tested our woodworking chops and allowed us to flaunt some beautiful joinery—creating a design that delights those charmed by its silhouette and those who appreciate its high craft.



Bumper Ottomans | Hecks Ottomans | Hecks Ottoman Trays

Strut Tables | Host Task Chairs | Beau Table Lamps | Basis Privacy Panels

AT YOUR SERVICE.



ALL
THE
DIGITAL
TOOLS
TO GET
IT DONE

Free
swatches

CUSTOM
DESIGN
RESOURCES

5-YEAR WARRANTY ON
ALL BLU DOT DESIGNS

3D Files
WYS
Specs

Good design
means being
committed
to a more
sustainable
future.

Learn more about our
commitment at bludot.com.

BIFMA
TESTED

Putting spaces together is hard work but fun work. To make sure your project goes smoothly, we've gathered everything you need, including a talented team of real people happy to help.



Trade +
Contract



NEW YORK
WASHINGTON, DC
MIAMI
CHICAGO
AUSTIN
LOS ANGELES
SAN FRANCISCO
PORTLAND
SEATTLE
DALLAS
MEXICO CITY
MONTERREY
SYDNEY
+ MORE



TRADE + CONTRACT

trade@bludot.com
844.425.8368x4
M-F, 9-5 CT

Real (talented) humans
at the ready.

Sign up for a trade account
at [BLUDOT.COM/TRADE](https://bludot.com/trade).

1321 Tyler Street NE
Minneapolis, MN 55413

©2022 Blu Dot Design & Manufacturing, Inc. All rights reserved. Blu Dot is a registered trademark of Blu Dot Design & Manufacturing, Inc.

Blu Dot reserves all rights to all furnishings it designs and produces. It is company policy to apply for design patents and copyrights on all designs, and to vigorously protect all intellectual property owned by Blu Dot against infringement and misuse. Accordingly, no designs may be reproduced, in any form or material, without the prior permission of Blu Dot. The information contained in this catalog was correct at the time of printing. Blu Dot reserves the right to make changes in design and construction or discontinue products without prior notification.

